

2V

AICON SIDE SCAN 2-VIEW

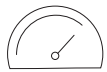

The most advanced, high-tech dual beam X-ray inspection system on the market right now. This system has been designed for the precise quality control of products in high packaging, such as jars, bottles, cans, PET, cardboard boxes, tubes and more. Providing excellent safeguarding against contamination and other quality deficiencies, this X-ray inspection system will protect both your product and your brand image.



150 m/min
Speed



10 Gb/s
Processing



60.000 pcs/h
Performance

ADVANCED X-RAY INSPECTION SYSTEM FOR QUALITY CONTROL OF HIGH VERTICAL PRODUCTS

ADVANTAGES

- **Effective detection** - the highest detection level (POD) of metallic contamination, glass, stones, calcified bones, Teflon, ceramics, dense plastics, product lumps and more, with the lowest false rejection rate (FRR).
- **High-performance** - an innovative data processing method, supporting production lines of up to 60.000 pcs/h.
- **Multifunctional** - thanks to the industry-record number of image analysis algorithms, AICON X-RAY detectors can efficiently handle any type of application.
- **Flexible configuration** - versatile configuration options to suit a wide range of applications.
- **Traceable** - full product history (including the manufacturing process) and easy access to a detailed archive data for quality control.
- **Simple integration** - the turn-key solution enables uncomplicated and quick integration into the production environment.

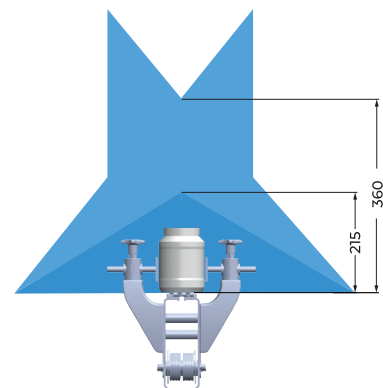

Beam geometry

TECHNOLOGY

- **High-efficiency, multi-threaded data processing** - the industry's highest multi-threaded data processing speeds - up to 10 Gb/s - for the most efficient image processing and maximum performance of the entire inspection system.
- **Self-control system** - AICON SIDE SCAN series devices are equipped with advanced built-in self-control system. This system guarantees stable operation of software and hardware, based on dual communication and redundant data processing. Devices built according to this concept perform continuous self-control in order to capture their own malfunctions at all stages of the product scanning process, from image creation to image analysis, through to reject of non-compliant product and the supervision of data acquisition.
- **Inverted inspection logic** - by default, AICON X-Ray devices treat every inspected product as non-compliant and therefore deemed to be rejected. It is only during the scanning process that the system analyses and determines whether the product meets the expected quality requirements, and whether its status can be changed to compliant. This inverted product inspection logic system greatly minimizes the risk of non-compliant products making it to market, even in the event of failure of any component in the inspection system.
- **Advanced tracking system** - comprehensive product flow control is performed in real time, ensuring precise tracking and reliable registration of the position of each product transported - regardless of line throughput or complexity of the production process.

FEATURES

- **An intelligent, ergonomic design** - ergonomic solutions ensure comfortable operation and allow for easy and quick system adjustment, should you need to replace individual consumable components. Plus, these systems have been designed to the highest standard of hygiene for easy maintenance regardless of manufacturing conditions.
- **Simple and easy to use** - simple and convenient operation, thanks to the highly ergonomic system and automated product learning.
- **Interface personalization** - flexibility to adjust the control panel to suit individual user requirements, allowing for higher operational comfort.
- **Full MES integration** - intelligent integration into the production environment and vast compatibility with current industry standards guarantee seamless communication of the X-ray detection system with key devices in the production line (including EtherNet/IP, PROFINET, S7, EtherCAT, Modbus-TCP, Profibus, CAN, CANopen, OPC UA, SQL, Siemens Standard and RS).

See more
on our website



TECHNICAL SPECIFICATION

AICON SIDE SCAN 2-VIEW

Troughput	≤ 60.000 pcs/h
Detection area	360 mm x 150 mm (H x B)
Diode resolution	0,4 mm – 0,8 mm
X-ray source	35-100 kV / 1.0-8.0 mA, 500 W
Number of scanning beams	2
Beam direction	Horizontal, Diagonal
X-ray emission	<1 μSv / h, the product complies with legal EU directives
Cooling	Dry Air Cooling system
Operating environment	Temperature: 0 - 45 ° C, humidity: 30 - 95%, non-condensing
Ingress Protection	IP65 (optional IP69)
Construction material	Bead-blasted stainless steel 1.4301 (AISI 304)
Display	TFT LCD 17" Touchscreen
Operating system	Windows 10 Enterprise
Software	AiSoft
Number of product programmes	1000
Disk space	500 GB for x-ray pictures and internal data storage, expandable
Communication interfaces	Ethernet 10/100/1000 mbps, USB 3.0 for external data storage
Air requirement	Min. 6 bar for pneumatic rejection systems
Power supply	Single phase, 230 VAC +/- 10%, fuse 12 A
Dimensions	1475 mm x 1484 mm x 1979 mm (L x B x H)

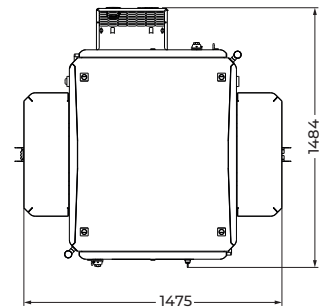
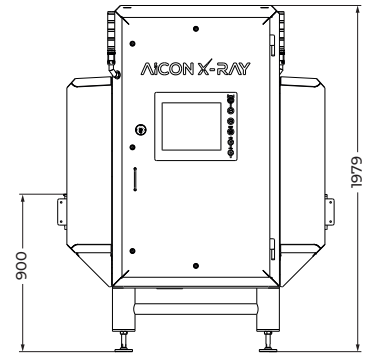

İLETİŞİM SİSTEMLERİ SAN. ve TİC. LTD. ŞTİ.

İnönü Mah. Elmadağ Cad. Harbiye Çayırı Sok. No.3 / 11 34373 Şişli İstanbul- Türkiye

Telefon: +90 212 343 48 12 • Faks: +90 212 250 96 39 • duba@duba.com.tr • www.duba.com.tr

AICON X-RAY
IMAGING QUALITY