

EUROCODE SERIES

MAGAZINE LOADING, HIGH SPEED,
HOT FOIL OVERPRINTERS

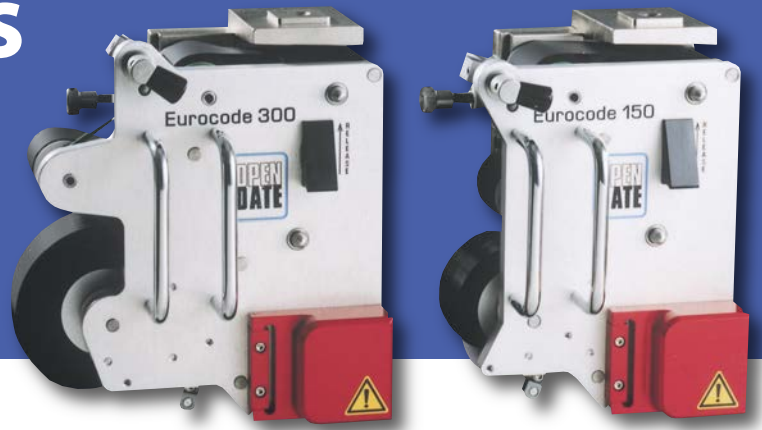

FEATURES

- ▶ Lightweight foil magazine
- ▶ 153 or 305m (500 or 1000ft) foil capacity
- ▶ 183m (600ft) foil capacity – US market
- ▶ Capable of more than 700 prints per minute
- ▶ Modest overall dimensions
- ▶ Easy to install on packaging and labelling machines
- ▶ Digital electronic control unit with fault display
- ▶ Quality engineered product
- ▶ Fully variable temperature control
- ▶ Interlocked type holder access door
- ▶ Uses flickwheel or standard type systems
- ▶ End of foil alarm – optional
- ▶ Printer fault signal
- ▶ Robust alloy air motor
- ▶ Full safety specification

The Eurocode is a small, lightweight, user friendly Hot Foil Coding attachment typically used for overprinting text (batch and lot code information, expiry and use by dates, price marking) as well as simple graphics in any colour, on to flexible packaging materials at speeds of up to 700 cycles per minute. Prints are clear, dry, non-toxic, and are of a quality that cannot be matched by any other on-line printing process.



World Class Coding & Marking Systems



getting you
up to speed

EUROCODE SERIES



SPECIFICATIONS

	EUROCODE 150/180	EUROCODE 300
Foil Capacity	153/183m (500/600ft)	305m (1000ft)
Print Head Dimensions	136 x 152 x 203mm	136 x 218 x 203mm
Print Area	40 x 28mm	
Operating Speed – Maximum	700 per minute	
End of Foil Alarm	Optional	
Air Cylinder	44 dia x 13mm	
Foil Width – Maximum	41mm	
Foil Feed Adjustment	Positive, accurate and infinitely adjustable	
Cycle Time – Minimum	80 milliseconds	
Free Air Consumption per Cycle	254cc @ 6.8 bar	
Operating Air Pressure	4.0 to 6.8 bar (60 to 100 PSI)	
Print Head Weight	4kg (8.5lbs)	
Dwell Time Range	12 - 650 milliseconds	
Temperature Range	Variable between 70 and 220°C	
Operating Voltage	110/240v AC, 50/60 Hz	
Control Unit Dimensions	240 x 145 x 66mm	

INSTALLATION DETAILS

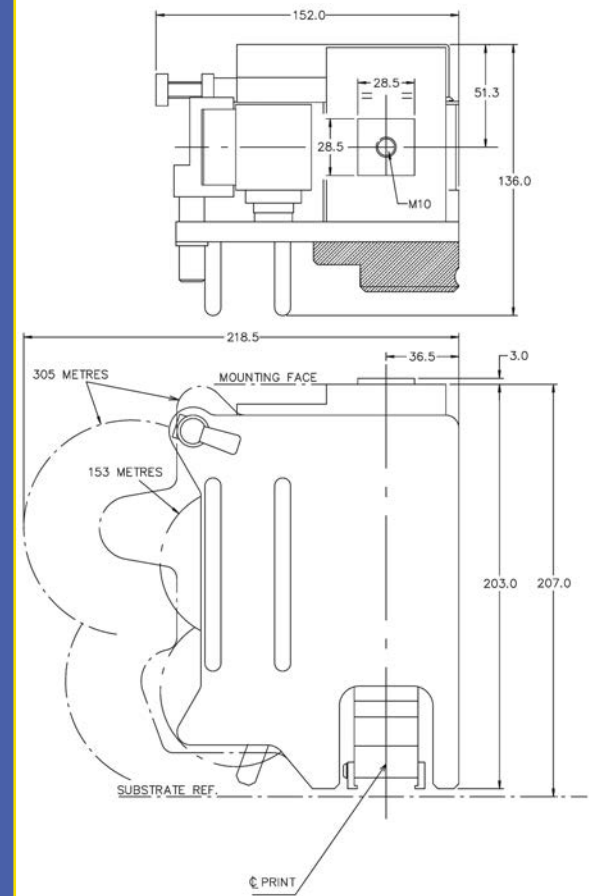

MOUNTING FRAME

The optional Eurocode mounting frame is the basis for most installations. It can be supplied in a standard form or ready adapted to suit specific host machinery.



CONTROL UNIT



The Eurocode's digital display controller enables simple yet precise control of print dwell times and operating temperatures to provide the optimum print quality. It features indicators for end of foil, open door, heater failure and temperature sensor failure.

PPMA

**OPEN
DATE**

Open Date Equipment Ltd.
Units 8 & 9 Puma Trade Park
145 Morden Road
Mitcham, Surrey, CR4 4DG.
UNITED KINGDOM
Tel: +44 (0)20 8655 4999
Fax: +44 (0)20 8655 4990
Email: sales@opendate.co.uk
Web site: www.opendate.co.uk

Open Date Systems, Inc.
Springfield Road, PO Box 538
Georges Mills, NH 03751
U.S.A.
Tel: +(1) 603 763 3444
Fax: +(1) 603 763 4222
Toll free: 877-OPENDATE
Email: info@opendate.com
Web site: www.opendate.com

Open Date France
Z.I. D'Attichy
60350 Attichy
France
Tel: +33 (0) 344 42 94 43
Fax: +33 (0) 344 42 17 17
Email: info@opendatefrance.com
Web site: www.opendatefrance.com

Open Date GmbH
Mittlere Stämmig 4
97297 Üttingen
Germany
Tel: +49 (0) 9369 98 24 0
Fax: +49 (0) 9369 98 24 24
Email: info@opendate.de
Web Site: www.opendate.de